

# ARTcessories™

Creative audio solutions in cool little boxes.

March 2003

## CleanBOX

### Two Way Stereo Converter

*Problem: You have a stereo output from a CD player (tape deck, VCR, computer sound card or other consumer electronics gear) and you need to connect it to the balanced line inputs of your mixer (EQ or other piece of professional audio equipment). Actually, there are three problems: 1.) Your source has RCA connectors and you need to connect to an XLR input. 2.) Your source signal is unbalanced, but you require a balanced signal where you're plugging into. 3.) The signal levels have to be matched properly.*

**Solution:** Use a CleanBOX! It's RCA-to-XLR channel 1 takes RCA signal, matches the signal levels and then provides a balanced (XLR) output.

*Problem: You have the balanced stereo output of a mixer (an EQ or other piece of pro audio gear) and need to connect it to the inputs of a cassette deck, computer sound card, VCR or another type of consumer electronics unit. The three problems above apply here as well (except your source is balanced, and you require an unbalanced audio signal).*

**Solution:** Use a CleanBOX! Its XLR-to-RCA channel 2 takes a XLR balanced signal, matches the signal levels and then provides an unbalanced (RCA) output.

*Problem: You want to mix your voice (and/or instrument) with a CD and record the mix on a cassette deck or computer. Now you need to interconnect three pieces of equipment; two consumer level and one balanced pro audio level (the mixer). You have to go from unbalanced RCA to balanced XLR and from balanced XLR back to unbalanced RCA.*

**Solution:** Simply use both channels on your CleanBOX.

### Specifications:

- Balancing, unbalancing and gain adjustment all in one simple unit.
- Dual channels – RCA unbalanced-to-XLR balanced and XLR balanced-to-RCA unbalanced
- Dual female RCA inputs and outputs plus dual XLR female Ins & male Outs
- Dual level controls, one for each channel
- Maximum Output Level: +18dB BAL, +12dB unbalanced
- Maximum Input Level: +22dB balanced and unbalanced
- S/N Ratio: >90dB
- Input Gain: -8dB balanced/+20dB unbalanced
- Power: 12V DC (Adapter Included)
- Dimensions: 4.625 x 5.625 x 1.75 inches (92mm x 142mm x 45mm)
- Weight: 1.6lbs. (725g)

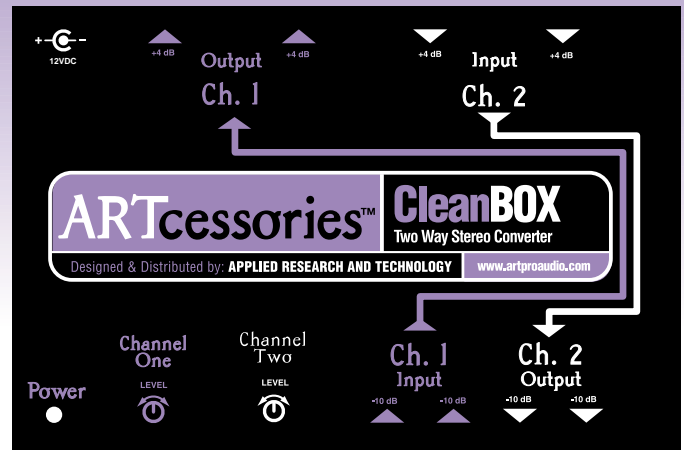

### Usage:

Connect the power adapter to the 12V DC connector on the CleanBOX and plug the other end into a 120V AC power outlet.

Unbalanced-to-Balanced: RCA to XLR

- a.) Connect the L/R stereo outputs of the consumer-level unit (CD player, cassette deck, VCR, etc.) to the CleanBOX's -10dB input CA connectors.
- b.) Connect the CleanBOX's +4dB Out male XLRs to the balanced inputs on the pro audio unit (two channels from a mixer) with two low-impedance XLR cables.
- c.) Adjust the Ch 1 Level control as required for best signal strength and clarity.

Balanced-to-Unbalanced: XLR to RCA

- a.) Connect the L/R balanced outputs from your pro-level unit (i.e. mixer) to the CleanBOX's +4dB In female XLRs with two low-impedance mic cables.
- b.) Connect the CleanBOX's -10dB Out female RCA connectors to the L/R inputs on your cassette deck (computer sound card, VCR, etc.) with an RCA to RCA cable. Adjust the Ch 2 Level control for best signal strength and clarity.

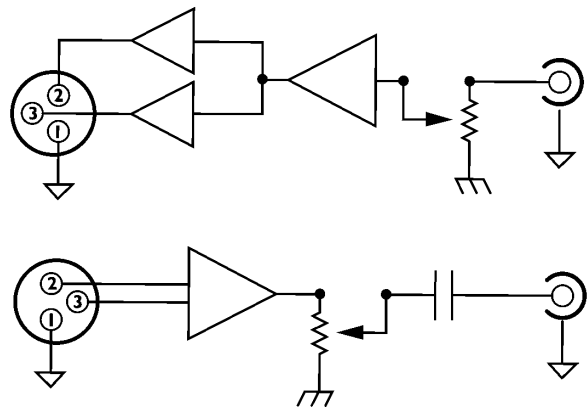

90 DAY  
WARRANTY

ART  
APPLIED RESEARCH AND TECHNOLOGY

DESIGNED & DISTRIBUTED BY: APPLIED RESEARCH AND TECHNOLOGY • 215 Tremont Street • Rochester, New York 14608 • USA  
For Customer Service, please call: 585.436.2720 • Email: cserve@artproaudio.com • www.artproaudio.com • ART-ARTcs-03/03